

USB-2408 Series

24-Bit Multifunction Temperature and Voltage Devices

USB-2408

USB-2408-2AO

User's Guide

Your new Measurement Computing product comes with a fantastic extra –

Management committed to your satisfaction!

Refer to www.mccdaq.com/execteam.html for the names, titles, and contact information of each key executive at Measurement Computing.

Thank you for choosing a Measurement Computing product – and congratulations! You own the finest, and you can now enjoy the protection of the most comprehensive warranties and unmatched phone tech support. It's the embodiment of our mission:

To provide data acquisition hardware and software that will save time and save money.

Simple installations minimize the time between setting up your system and actually making measurements. We offer quick and simple access to outstanding live FREE technical support to help integrate MCC products into a DAQ system.

Limited Lifetime Warranty: Most MCC products are covered by a limited lifetime warranty against defects in materials or workmanship for the life of the product, to the original purchaser, unless otherwise noted. Any products found to be defective in material or workmanship will be repaired, replaced with same or similar device, or refunded at MCC's discretion. For specific information, please refer to the terms and conditions of sale.

Harsh Environment Warranty® Program: Any Measurement Computing product that is damaged due to misuse, or any reason, may be eligible for replacement with the same or similar device for 50% of the current list price. I/O boards face some harsh environments, some harsher than the boards are designed to withstand. Contact MCC to determine your product's eligibility for this program

30 Day Money-Back Guarantee: Any Measurement Computing Corporation product may be returned within 30 days of purchase for a full refund of the price paid for the product being returned. If you are not satisfied, or chose the wrong product by mistake, you do not have to keep it.

These warranties are in lieu of all other warranties, expressed or implied, including any implied warranty of merchantability or fitness for a particular application. The remedies provided herein are the buyer's sole and exclusive remedies. Neither Measurement Computing Corporation, nor its employees shall be liable for any direct or indirect, special, incidental or consequential damage arising from the use of its products, even if Measurement Computing Corporation has been notified in advance of the possibility of such damages.

Trademark and Copyright Information

Measurement Computing Corporation, InstaCal, Universal Library, and the Measurement Computing logo are either trademarks or registered trademarks of Measurement Computing Corporation. Refer to the Copyrights & Trademarks section on mccdaq.com/legal for more information about Measurement Computing trademarks. Other product and company names mentioned herein are trademarks or trade names of their respective companies.

© 2011-2012 Measurement Computing Corporation. All rights reserved. No part of this publication may be reproduced, stored in a retrieval system, or transmitted, in any form by any means, electronic, mechanical, by photocopying, recording, or otherwise without the prior written permission of Measurement Computing Corporation.

Notice

Measurement Computing Corporation does not authorize any Measurement Computing Corporation product for use in life support systems and/or devices without prior written consent from Measurement Computing Corporation. Life support devices/systems are devices or systems that, a) are intended for surgical implantation into the body, or b) support or sustain life and whose failure to perform can be reasonably expected to result in injury. Measurement Computing Corporation products are not designed with the components required, and are not subject to the testing required to ensure a level of reliability suitable for the treatment and diagnosis of people.

Table of Contents

About this User's Guide	5
What you will learn from this user's guide	5
Conventions in this user's guide	5
Where to find more information	5
Chapter 1	
Introducing the USB-2408 Series	6
Overview: USB-2408 Series features	6
USB-2408 Series block diagram	7
Chapter 2	
Installing a USB-2408 Series Device	8
What comes with your shipment?.....	8
Hardware	8
Documentation.....	8
Unpacking.....	8
Installing the software	9
DAQFlex	9
Universal Library and InstaCal	9
Installing the hardware	9
Calibrating	10
Self-calibration	10
Factory calibration	10
Programming and developing applications.....	10
Chapter 3	
Functional Details	11
External components	11
USB connector.....	11
LEDs.....	11
Screw terminals.....	12
Signal connections.....	13
Input isolation	13
Analog/TC input	14
Analog input mode.....	14
Gain queue.....	15
TC input mode	16
Analog output (USB-2408-2AO only).....	18
Digital I/O.....	18
Internal pull-up/pull-down capability.....	19
External pull-up/pull-down capability	21
Counter input	21
Ground.....	21
Mechanical drawings.....	22
Chapter 4	
Specifications	23
Analog input	23
Channel configurations.....	24
Compatible sensors	24
Accuracy.....	24

Thermocouple measurement accuracy	24
Analog input DC voltage measurement accuracy	25
Input bandwidth	26
Noise performance	26
Channel switching error	27
Throughput rate	27
Analog voltage output (USB-2408-2AO only)	28
Analog input/output calibration	29
Digital input/output	29
Counter	30
Memory	31
Microcontroller	31
Power	31
USB specifications	31
Environmental	31
Mechanical	32
Screw terminal connector type and pinout	32
Screw terminal pinout	33
Declaration of Conformity	35

About this User's Guide

What you will learn from this user's guide

This user's guide describes the Measurement Computing USB-2408 Series data acquisition devices and lists device specifications.

Conventions in this user's guide

For more information about ...

Text presented in a box signifies additional information and helpful hints related to the subject matter you are reading.

Caution! Shaded caution statements present information to help you avoid injuring yourself and others, damaging your hardware, or losing your data.

bold text **Bold** text is used for the names of objects on a screen, such as buttons, text boxes, and check boxes.

italic text *Italic* text is used for the names of manuals and help topic titles, and to emphasize a word or phrase.

Where to find more information

Additional information about USB-2408 Series hardware is available on our website at www.mccdaq.com. You can also contact Measurement Computing Corporation by phone, fax, or email with specific questions.

- Phone: 508-946-5100 and follow the instructions for reaching Tech Support.
- Fax: 508-946-9500 to the attention of Tech Support
- Email: techsupport@mccdaq.com

Introducing the USB-2408 Series

Overview: USB-2408 Series features

The USB-2408 Series includes the following devices:

- USB-2408
- USB-2408-2AO

These devices are USB 2.0 full-speed devices that are supported under the following operating systems:

- Microsoft Windows 7/Vista/XP (32-bit or 64-bit)
- Microsoft Windows CE
- Macintosh (32-bit or 64-bit)
- Linux (32-bit or 64-bit)

Each USB-2408 Series device provides the following features:

- 16 single-ended (SE) or eight differential (DIFF) 24-bit analog inputs with sampling rates up to 1 kS/s. Each channel is software-configurable as SE or DIFF. For each DIFF channel pair, you lose one SE channel.
- Analog input ranges of ± 10 V, ± 5 V, ± 2.5 V, ± 1.25 V, ± 0.625 V, ± 0.312 V, ± 0.156 V, and ± 0.078 V.
- Up to eight analog inputs can be configured as DIFF thermocouple (TC) inputs, which include built-in cold-junction compensation and open TC detection.
- Computer protection provided through a minimum of 500 VDC input isolation between field wiring and the USB interface.
- Eight lines of digital I/O and two 32-bit counters.
- Screw terminals for field wiring connections

The USB-2408-2AO also provides two 16-bit analog output channels. You can pace a single channel at rates of up to 1 kS/s. You can pace both channels simultaneously at rates of up to 500 S/s.

USB-2408 Series block diagram

USB-2408 Series functions are illustrated in the block diagram shown here.

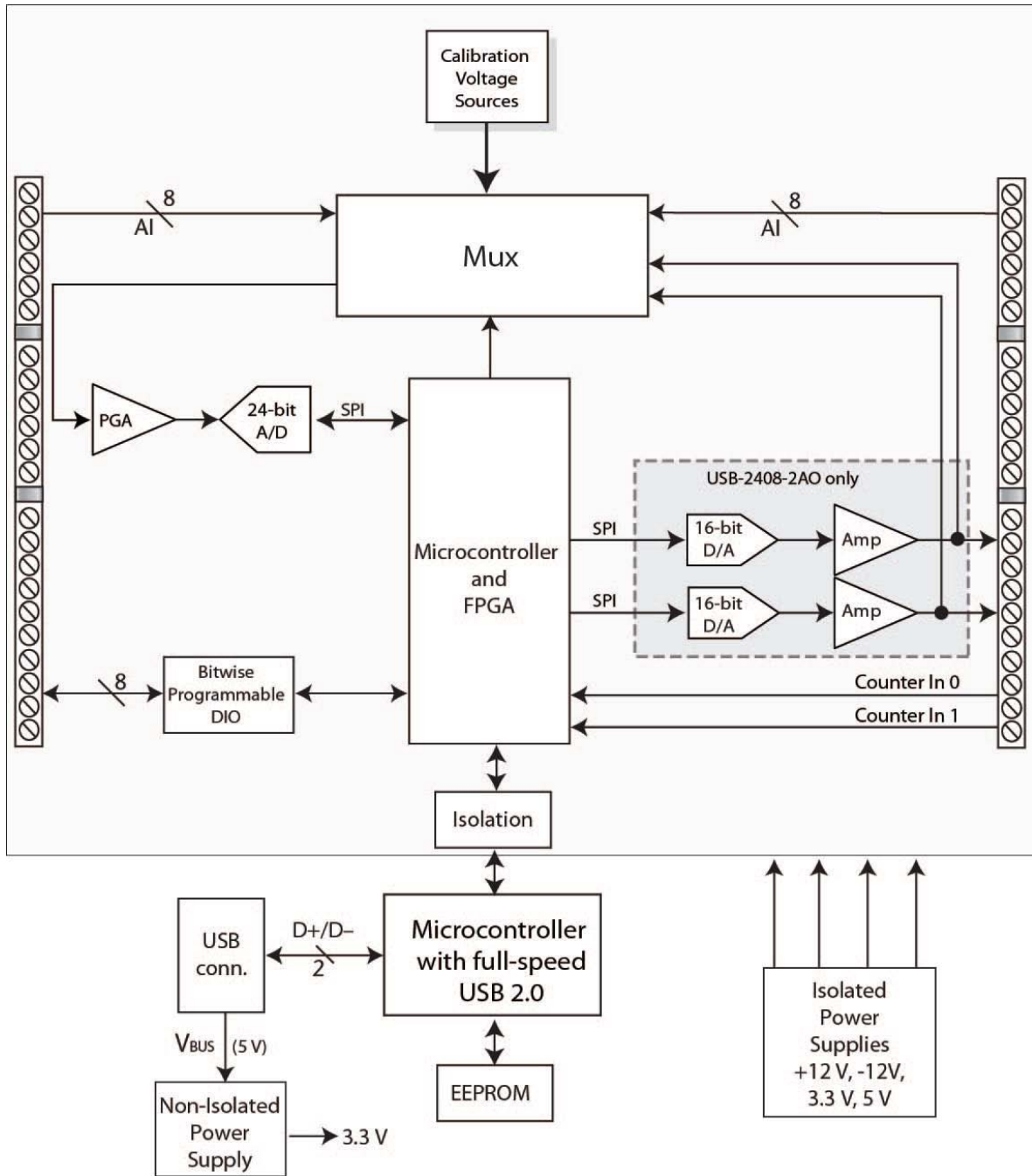

Figure 1. USB-2408 Series functional block diagram

Installing a USB-2408 Series Device

What comes with your shipment?

As you unpack your USB-2408 Series device, verify that the following components are included.

Hardware

- USB-2408 Series device (USB-2408 or USB-2408-2AO)



- USB cable (2-meter length)

Documentation

In addition to this hardware user's guide, a *Quick Start Guide* booklet is included with the USB-2408 Series shipment. This booklet provides an overview of the MCC DAQ software you received with the device, and includes information about installing the software. Please read this booklet completely before installing any software or hardware.

Unpacking

As with any electronic device, take care while handling to avoid damage from static electricity. Before removing the USB-2408 Series device from its packaging, ground yourself using a wrist strap or by simply touching the computer chassis or other grounded object to eliminate any stored static charge.

If the device is damaged, notify Measurement Computing Corporation immediately by phone, fax, or e-mail.

- Phone: 508-946-5100 and follow the instructions for reaching Tech Support.
- Fax: 508-946-9500 to the attention of Tech Support
- Email: techsupport@mccdaq.com

For international customers, contact your local distributor. Refer to the "International Distributors" section on our web site at www.mccdaq.com/contact2.aspx.

Installing the software

Note: Before installing a USB-2408 Series device, you must install the software you plan to use with the device.

The USB-2408 Series is supported by DAQFlex software and Universal Library and InstaCal software. You can install both software packages on your computer. However, you cannot run both software packages simultaneously with one USB-2408 Series device.

DAQFlex

Install DAQFlex software when you want to develop data acquisition applications that can be deployed across multiple operating systems and custom embedded systems.

DAQFlex software for each supported operating system is available from the DAQFlex download page at www.mccdaq.com/DAQFlexDL. Refer to the *DAQFlex Software User's Guide* at www.mccdaq.com/pdfs/manuals/DAQFlex%20Software.pdf for instructions about installing DAQFlex software.

Universal Library and InstaCal

Install Universal Library and InstaCal when you want to develop data acquisition applications using Windows programming languages.

Universal Library and InstaCal software are included on the CD that ships with the device. Refer to the *Quick Start Guide* booklet for instructions about installing Universal Library and InstaCal software.

Installing the hardware

Install the software before you install your device

A driver needed to run the USB-2408 Series device is installed when you install the software. Therefore, you need to install the software package you plan to use before you install the hardware.

For operation on a Windows operating system, we recommend that you run Windows Update to update your operating system with the latest USB drivers.

To connect a USB-2408 Series device to your system, turn on your computer and connect the USB cable to an available USB port on the computer or to an external USB hub connected to the computer. Connect the other end of the USB cable to the USB connector on the device. No external power is required.

When you connect the device for the first time to a computer running Windows, a **Found New Hardware** dialog opens when the operating system detects the device. The dialog closes after the device is installed.

A green **Status** LED indicates the device status. When the LED is on, the device is powered and ready for operation. If the LED is not on, the device is not powered or did not initialize.

Figure 2 on page 11 shows the location of the **STATUS** LED.

Mac OS X

When connecting the device to a computer running the Mac OS X operating system, the Status LED does not turn on until the device is configured by application software.

Caution! Do not disconnect any device from the USB bus while the computer is communicating with the USB-2408 Series device, or you may lose data and/or your ability to communicate with the device.

If the Status LED turns off

If the **Status** LED turns on but then turns off, the computer has lost communication with the USB-2408 Series device. To restore communication, disconnect the USB cable from the computer and then reconnect it. This should restore communication, and the **Status** LED should turn on.

Calibrating

Self-calibration

USB-2408 Series hardware supports self-calibration. You should calibrate the device whenever the ambient temperature changes by more than ± 10 °C from the last self-calibration. Use either InstaCal or the DAQFlex FlexTest utility to calibrate the device.

Factory calibration

The Measurement Computing Manufacturing Test department performs the initial factory calibration. Contact Measurement Computing for details about how to return your device and have it calibrated to the factory specifications.

Programming and developing applications

You can program and develop applications for the USB-2408 Series device using MCC DAQ software and DAQFlex software. OEM users can create a custom driver for use with the message-based firmware to interface with the device.

- Refer to the *Quick Start Guide* for information about the Universal Library and InstaCal.
- Refer to the [DAQFlex Software User's Guide](#) for information about DAQFlex software.
- Refer to the [Message-based Firmware Specification](#) for information about the message-based firmware.

Functional Details

External components

USB-2408 Series devices have the following external components:

- USB connector
- LEDs
- Screw terminals

Figure 2 shows the location of each component.

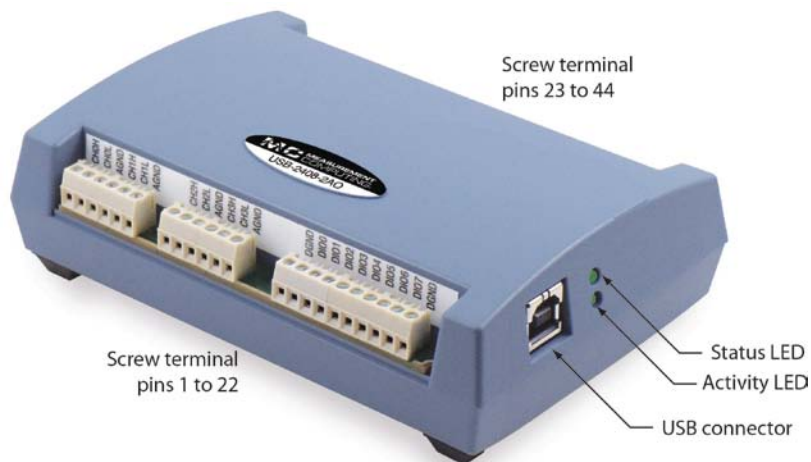

Figure 2. USB-2408 Series components

USB connector

The USB connector provides +5 V power and communication. No external power supply is required.

LEDs

USB-2408 Series devices have two LEDs – **STATUS** and **ACTIVITY**.

- The **Status** LED is lit when the device is detected and installed on the computer.
- The **Activity** LED indicates the communication status of a device. This LED blinks when data is transferred, and is off when the device is not communicating.

Figure 3 shows the location of each LED.

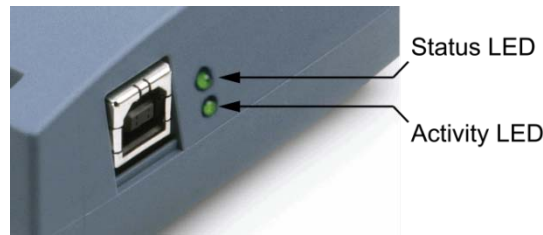

Figure 3. USB-2408 Series LEDs

Screw terminals

USB-2408 Series devices have two banks of screw terminals. Screw terminal functions for DIFF and SE modes are identified in Figure 5 and Figure 4.

The USB-2408 Series device screw terminals provide the following connections:

- 16 SE (**CH0** to **CH15** – see Figure 4) or eight DIFF (**CH0H/CH0L** to **CH7H/CH7L**) analog input connections
- Eight digital I/O connections (**DI00** to **DI07**)
- Two analog output connections (**AOUT0**, **AOUT1**) – *USB-2408-2AO only*
- Two counter inputs (**CTR0**, **CTR1**)
- One power output (**+5V**)
- 10 analog grounds (**AGND**), four digital grounds (**DGND**), and one chassis ground (**CHAS**)

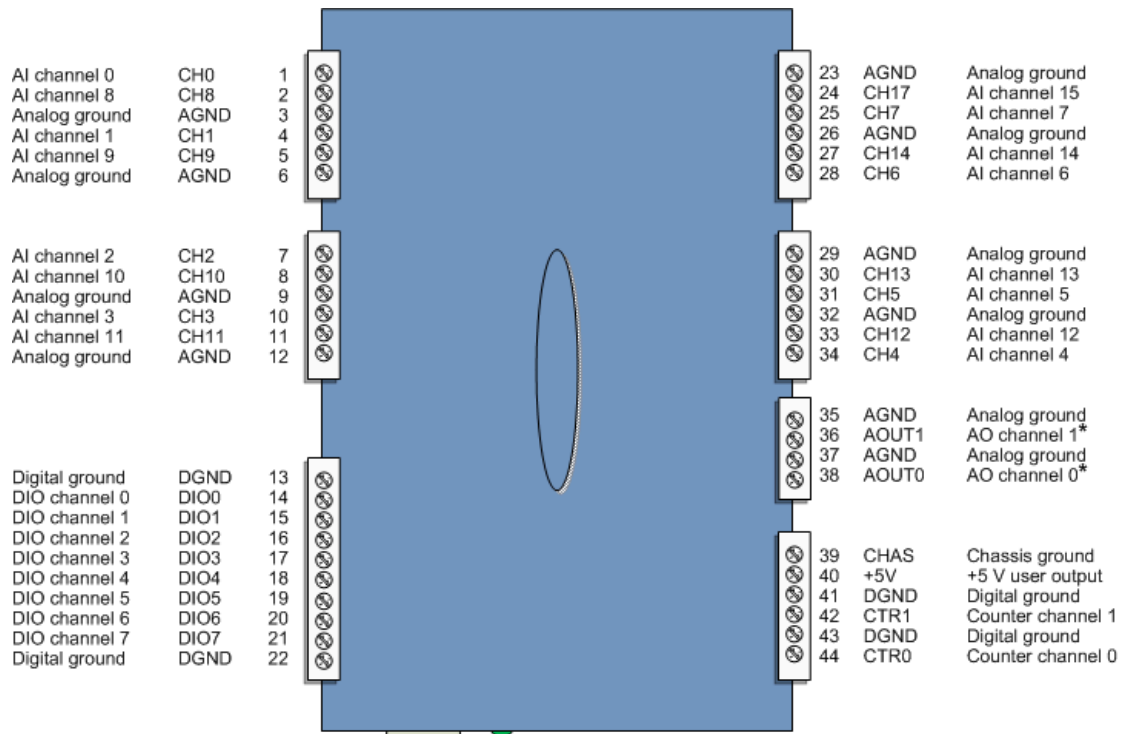

Figure 4. SE mode pin out

* These pins are labeled "NC" (no connection) on the USB-2408.

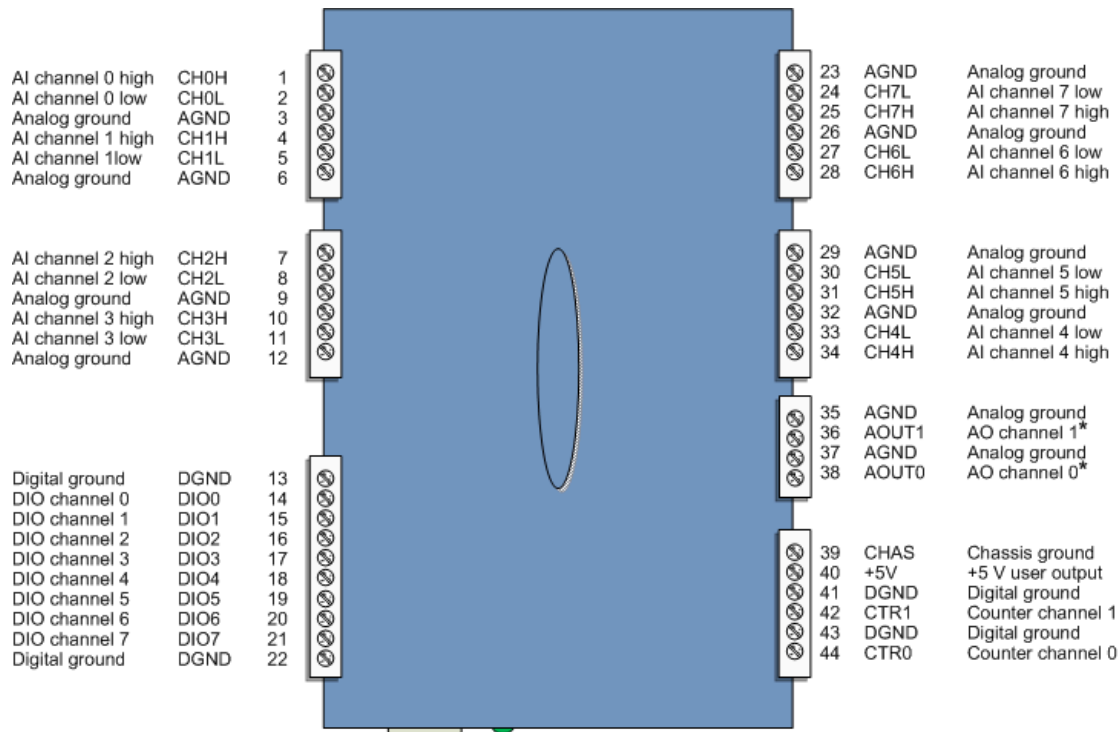

Figure 5. DIFF mode pin out

* These pins are labeled "NC" (no connection) on the USB-2408.

Signal connections

Input isolation

USB-2408 Series devices are isolated data acquisition devices. The analog I/O, digital I/O, counters, and all the digital control/timing are referenced to an isolated ground as shown in the figure below. This ground is physically and electrically separate from the ground used by the circuit connected to the system bus interface.

Isolation provides a barrier between the host computer and potentially hazardous voltages by physically and electrically separating two parts of the measurement device.

- The "non-isolated" ground is common to the chassis ground of the computer, while the "isolated" ground is not.
- All analog measurements are made relative to the isolated ground. See Figure 6 for details.

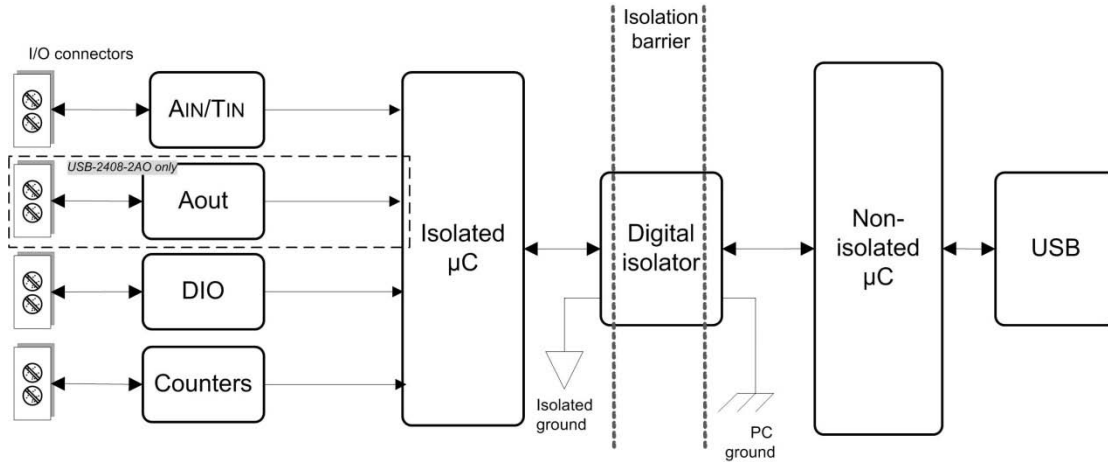

Figure 6. USB-2408 Series input isolation diagram

When making measurements in industrial environments, DAQ devices can encounter hazardous voltages, transients, large common mode voltages and fluctuating ground potentials. Any one of these issues can seriously degrade the measurement accuracy of the device and possibly damage the measurement instrument. To overcome these issues, some DAQ devices provide physical and electrical isolation. Some of the benefits of isolation include:

- **Safety:** A DAQ device employing physical and electrical isolation helps to keep high voltages and transients from damaging the system-side host computer.
- **Ground loops:** Improper grounding of the signal source that the DAQ device is measuring is one of the most common sources of noise and measurement inaccuracies. Isolation improves the measurement accuracy by physically preventing ground loops. Ground loops – a common source of noise and error – are the results of a measurement system having multiple grounds at different potentials.
- **Common mode rejection:** With isolation, a DAQ device can measure small signals in the presence of large common mode voltages. Isolation increases the ability of the measurement system to reject common mode voltages. The common mode voltage is the signal that is common to both the positive and negative inputs of the measurement device, but is not part of the signal to measure.

Analog/TC input

Each analog input channel has the following measurement parameters:

- Voltage input range
- TC type J, K, T, E, R, S, B, or N

You can select a unique input range or signal type for each channel. For example, one channel could be used for volts and another for temperature.

Analog input mode

You can configure the analog inputs for SE or DIFF mode. The input voltage range is software selectable for ± 10 V, ± 5 V, ± 2.5 V, ± 1.25 V, ± 0.625 V, ± 0.312 V, ± 0.156 V, or ± 0.078 V.

With SE mode, connect up to 16 inputs to screw terminals **CH0** to **CH15**. SE mode requires two wires:

- Connect one wire to the signal you want to measure (**CHx**).
- Connect one wire to the analog ground reference (**AGND**).

Refer to Figure 4 on page 12 for the location of the SE inputs.

With DIFF mode, connect up to eight differential inputs to screw terminals **CH0H/CH0L** to **CH7H/CH7L**. DIFF mode requires two wires plus a ground reference:

- Connect one wire to the high/positive signal (**CHxH**).
- Connect one wire to the low/negative signal (**CHxL**).
- Connect one wire to the analog ground reference (**AGND**).

Refer to Figure 5 on page 13 for the location of the DIFF inputs.

When connecting DIFF voltage inputs to a "floating" voltage source, make sure there is a DC return path from each voltage input to ground. You make this path by connecting a resistor from each low channel input to an AGND pin. A value of approximately 100 k Ω can be used for most applications. This does not apply to channels configured for TC input, as they have their own internal reference.

Leave unused input channels either floating or tied to an AGND terminal.

Source impedances should be kept as small as possible to avoid settling time and accuracy errors.

Figure 7 shows a DIFF voltage connection using a ground path resistor.

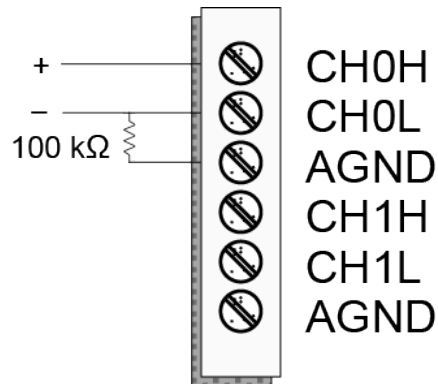

Figure 7. DIFF voltage connection with ground path resistor example

Gain queue

Use the USB-2408 Series channel - gain queue feature to configure a list of channels, modes, and gains for each scan. The settings are stored in a channel – gain queue list that is written to local memory on the device.

The channel - gain queue list contains one or more channel numbers and range settings. You can configure up to 64 elements. The channels can be listed in any order, and can include duplicate channels for sampling at different ranges.

An example of a 12-element list is shown in the table below.

Sample channel gain queue list

Element	Channel	Range
0	CH0	BIP10V
1	CH1	BIP5V
2	CH0	BIP2Pt5VOLTS
3	CH4	BIP2Pt5VOLTS
4	CH8	BIP2Pt5VOLTS
5	CH0	BIP5V
6	CH1	BIP1Pt25VOLTS
7	CH7	BIP5V
8	CH0	BIP1Pt25VOLTS
9	CH15	BIP10V
10	CH9	BIP1Pt25VOLTS
11	CH10	BIP2Pt5VOLTS

Carefully match the gain to the expected voltage range on the associated channel or an over range condition may occur. Although this condition does not damage the device, it does produce a useless full-scale reading, and can introduce a long recovery time due to saturation of the input channel.

For more information about analog signal connections

For more information about analog input connections, refer to the *Guide to Signal Connections* (this document is available on our web site at www.mccdaq.com/signals/signals.pdf).

TC input mode

You can make up to eight high-resolution DIFF TC measurements with a USB-2408 Series device. Built-in cold-junction compensation sensors are provided for each of the screw-terminal blocks and any supported TC type can be attached to any of the 8 TC channels.

Do not connect TCs as *SE* – doing so can cause false readings.

You do not need to use ground-referencing resistors for TC inputs because the analog front-end circuit level-shifts the TC output into the common-mode input range of the A/D.

USB-2408 Series devices also provide an open TC detection feature for each of the analog input channels configured for TC measurement. This feature is enabled or disabled by software, and when enabled, it detects if an open-circuit condition exists at the TC sensor.

USB-2408 Series devices provide electrostatic discharge (ESD) protection for each of the TC inputs. However, before handling TC sensors, follow standard ESD practices and discharge any accumulated ESD charge.

Once the TC sensor is connected to the device, the configuration options have been selected, and the recommended 45 minute warm up has elapsed, the device is ready to make high-resolution DIFF temperature measurements.

Built-in cold junction compensation (CJC) automatically compensates for the additional thermal EMFs generated by connecting the TC leads to the USB-2408 Series device terminal blocks.

CJC is performed using a high-resolution temperature sensor connected close to the device terminal blocks. The device includes two separate CJC sensors – one on each side of the PCB. Software corrects for the additional TCs created at the terminals.

Once the A/D and CJC data is collected, the application software uses this data to linearize to an accurate temperature reading. The TC linearization uses the latest NIST linearization coefficients for each of the eight TC types supported by USB-2408 Series devices.

When configuring TC sensors, keep any stray capacitance as small as possible relative to AGND to avoid settling time and accuracy errors. For TC channels, do not provide a return path to ground. This is done internally.

Figure 8 shows a typical TC connection.

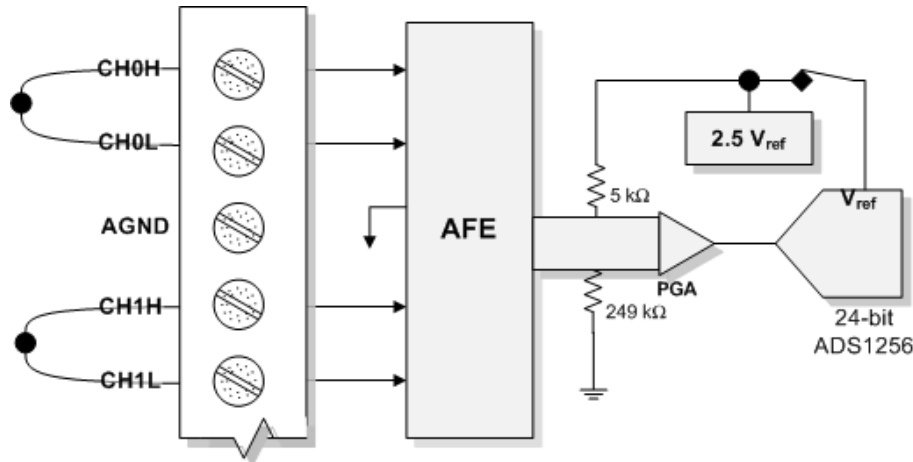

Figure 8. DIFF TC connection example

Noise filtering, data rate and throughput rate

Although the USB-2408 Series A/D converter has a maximum data rate of 3,750 samples per second, the actual throughput rate you observe for voltage and temperature data is determined by these formulas.

- Maximum single-channel throughput:

$$\frac{1}{\frac{1}{data\ rate} + 640\mu s}$$

- Maximum multiple-channel throughput:

$$\frac{1}{\sum_n \left(\frac{1}{data\ rate} + 640\mu s \right)}$$

where *n* is the number of channels

See Table 18 and Table 19 in the "Specifications" chapter for details.

This drop-off in throughput rate is due to the noise filtering feature in the device. You can control the amount of the noise filtering by adjusting the data rate setting. By reducing the data rate, the averaging of samples increases, and noise drops correspondingly.

Figure 9 illustrates this inverse relationship. This graph applies to the A/D converter only – do not expect this level of performance from a USB-2408 Series device itself.

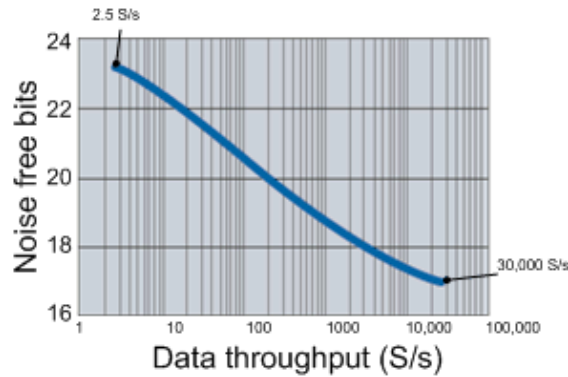

Figure 9. USB-2408 Series A/D converter data rate vs. noise graph

If low noise is your main concern, you can operate the USB-2408 Series device at very low data rates starting from 2.5 samples per second (S/s). At low rates, much of the noise is averaged out of the data, and issues such as reference noise become less important.

At higher data rates, higher-frequency noise sources are not averaged out and begin to be troublesome. These noise sources include the noise inherent in the A/D converter itself, which is not reducible.

Since TCs can pick up noise in your environment, select a data rate based on the primary noise frequency. For example, to reduce the effect of 60 Hz noise, select a data rate of 60 (or a supported submultiple of 60, such as 10 or 5).

Multiple-channel throughput rates

When setting different sample rates for channels, be aware that all the channels will be sampled within the same *sample window* based on the channel with the lowest sample rate.

For example, if you set a 10 Hz data rate for channel 0, and a 50 Hz data rate for channel 1, basically, both channels pass the same number of samples per second to the host computer. However, more averaging is performed on channel 0 samples; therefore, channel 0 is sampled at a higher resolution.

The USB-2408 Series A/D converter performs averaging, and the number of averages equals $30,000/\text{data rate}$.

In this example, channel 0 is sampled 3000 times over 100 ms, and all samples are averaged into one sample. Then, channel 1 is sampled 600 times over 20 ms, and samples are likewise averaged into one sample.

The final samples are available to you at a maximum rate of about 8 Hz (8.245 Hz).

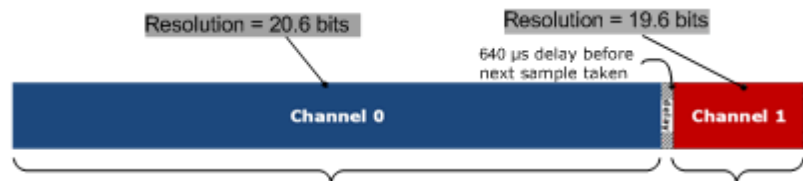

Figure 10. USB-2408 Series data rate vs. resolution example

Analog output (USB-2408-2AO only)

The USB-2408-2AO has two 16-bit analog outputs (**AOUT0** and **AOUT1**). Both outputs can be updated simultaneously at a rate of 500 S/s per channel. One output can be updated at a rate of 1000 S/s. The output range is fixed at ± 10 V. The outputs default to 0 V when the host computer is shut down or suspended, or when a reset command is issued to the device.

Digital I/O

You can connect up to eight digital I/O lines to **DIO0** through **DIO7**. The digital I/O terminals can detect the state of any TTL-level input.

Digital input voltage ranges of up to 0 to +15 V are permitted, with thresholds of 0.6 V (low) and 2.2 V (high).

Each DIO channel is an *open-drain*, which, when used as an output, is capable of sinking up to 150 mA for direct drive applications.

Figure 11 shows an example of a typical DIO connection.

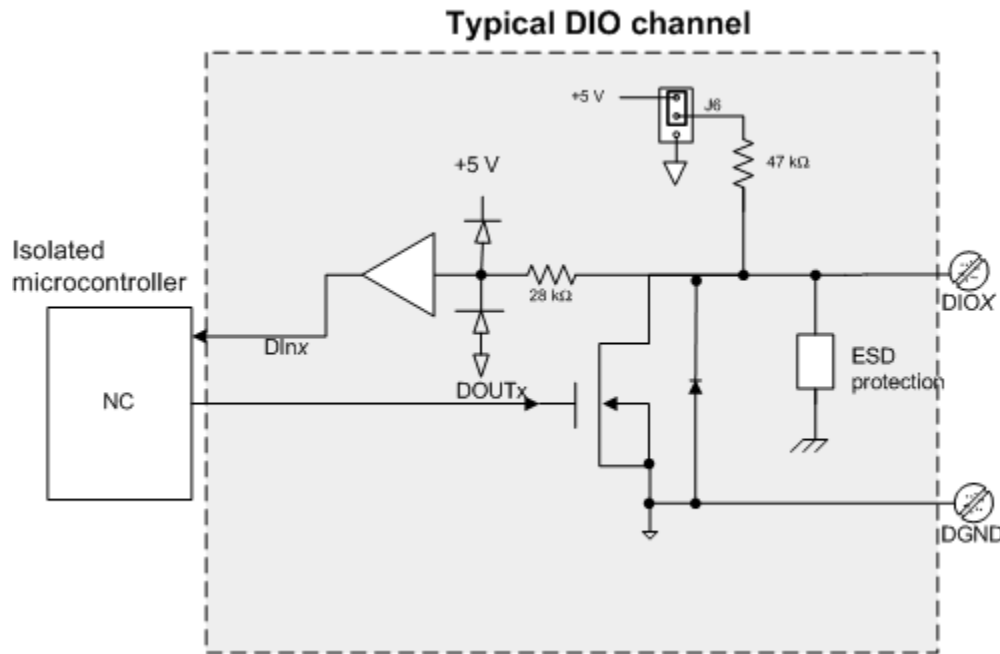

Figure 11. Digital output connection example

The figure represents connections for one channel. The other seven channels are connected in the same manner.

The maximum sink current is 150 mA per 8-channel bank, or if all eight channels are used, 18 mA (maximum) per channel.

Internal pull-up/pull-down capability

Unconnected inputs are pulled high by default to 5 V using 47 kΩ resistors through jumper **J6** on the circuit board. The pull-up/pull-down voltage is common to all 47 kΩ resistors. Complete the following steps to configure these inputs.

Caution! The discharge of static electricity can damage some electronic components. Before removing the USB-2408 Series device from its housing, ground yourself using a wrist strap or touch the computer chassis or other grounded object to eliminate any stored static charge.

To open the case and set the J6 jumper, do the following.

1. Turn the device over and rest the top of the housing on a flat, stable surface.
2. Peel off the four rubber feet on the bottom of the device to access the screws.
3. Remove the four screws from the bottom of the device.
4. Hold both the top and bottom sections together, turn the device over and rest it on the surface, then carefully remove the top section of the case to expose the circuit board.
5. Configure jumper **J6** for either pull-up (pins 1-2) or pull-down (pins 2-3). The jumper is configured by default for pull-up. Figure 12 shows the location of the jumper on the board.

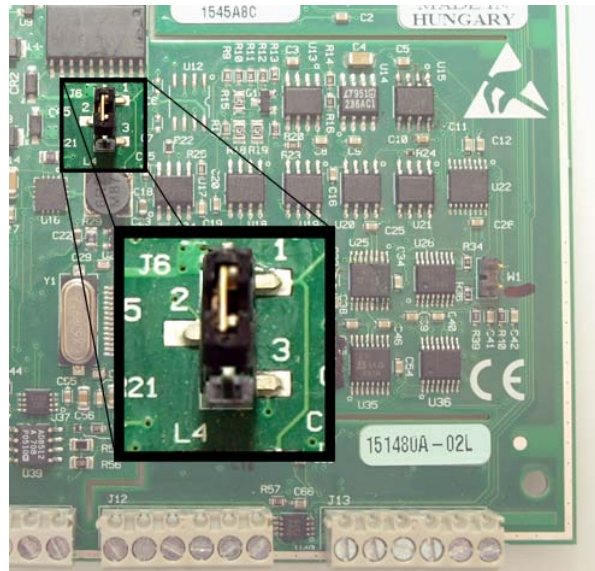

Figure 12. Location of J6 jumper

Figure 13 shows the jumper configured for pull-up and pull-down.

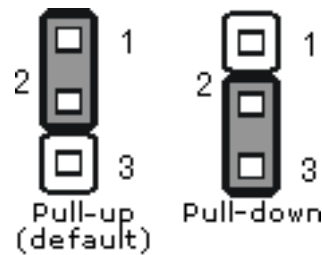

Figure 13. J6 jumper configurations

6. Replace the top section of the case, and fasten it to the bottom section with the four screws. Replace the rubber feet.

For more information about digital signal connections

For general information about digital signal connections and digital I/O techniques, refer to the *Guide to Signal Connections* (available on our web site at www.mccdaq.com/signals/signals.pdf).

The pull-up/pull-down voltage is common to all of the internal 47 kΩ resistors.

External pull-up/pull-down capability

You can also place an external pull-up resistor on any of the DIO bits, which enables you to pull the DIO bit up to a voltage that exceeds the internal +5 V pull-up voltage.

When using external pull-up resistors, be aware of the following:

- You should either remove the J6 jumper, or store it by attaching it to one of the three pins.
- When using external pull-up resistors, be aware that the internal resistors cause a slight voltage impedance shift to digital lines in the "on" state as various lines change between the on/off states.

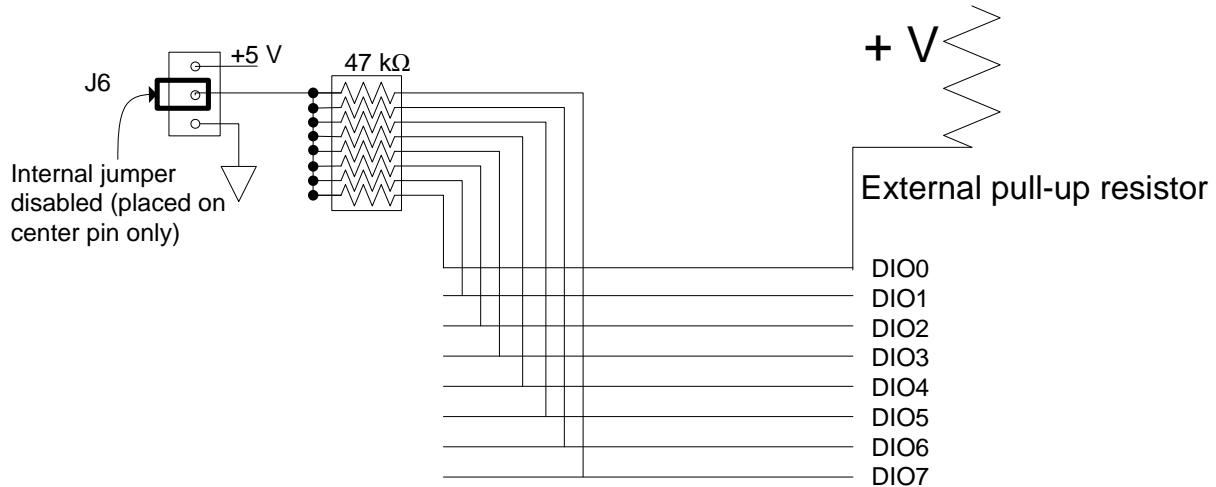

Figure 14. Digital I/O external resistor configuration

Counter input

The **CTR0** and **CTR1** terminals are 32-bit event counters that can accept frequency inputs up to 1 MHz. The internal counter increments when the TTL levels transition from low to high.

Ground

The analog ground (**AGND**) terminals provide a common ground for all analog channels.

The digital ground (**GND**) terminals provide a common ground for the digital and counter channels and the power terminal.

Mechanical drawings

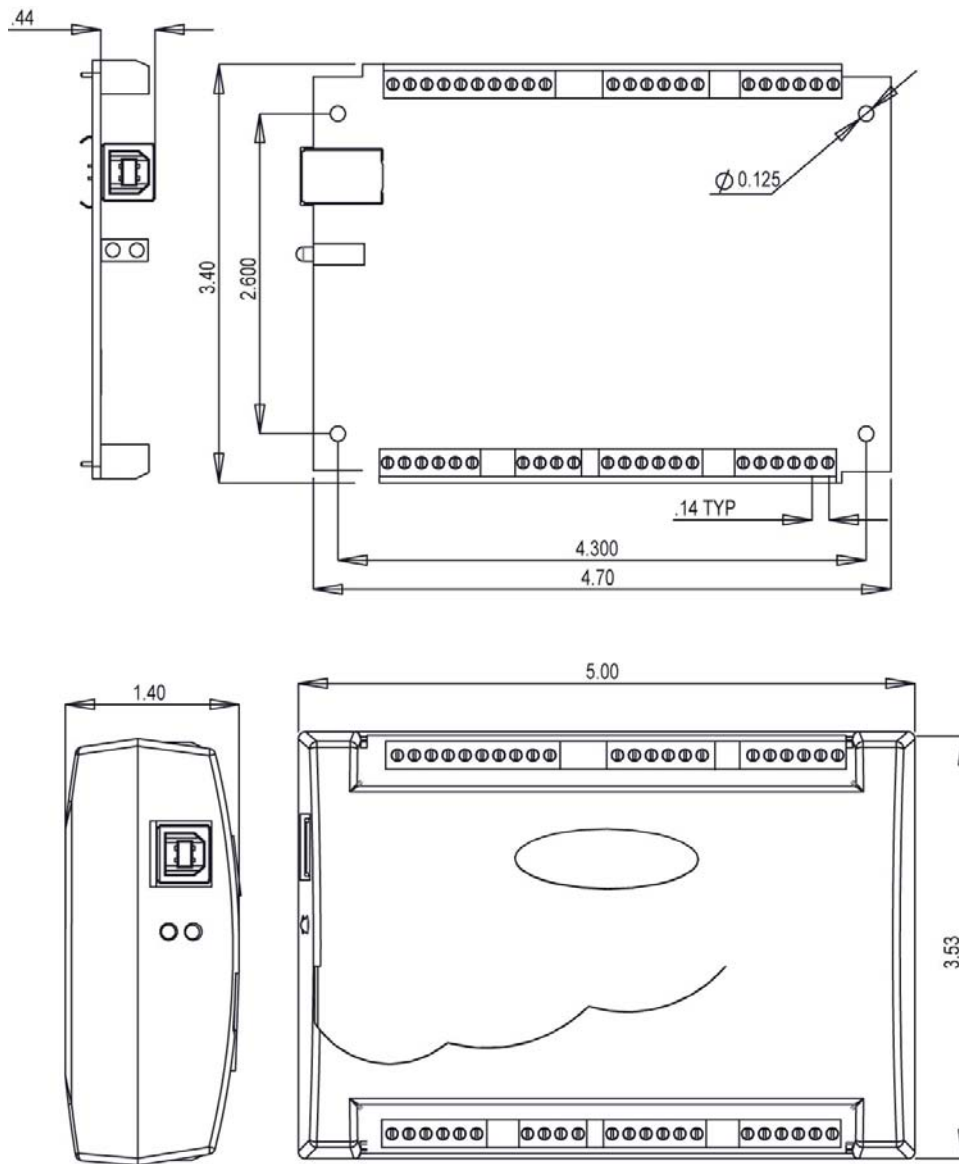

Figure 15. USB-2408 Series device circuit board (top) and enclosure dimensions

Specifications

All specifications are subject to change without notice.

Typical for 25 °C unless otherwise specified.

All specifications apply to all temperature and voltage input channels unless otherwise specified.

Specifications in *italic* text are guaranteed by design.

Analog input

Table 1. General analog input specifications

Parameter	Conditions	Specification
A/D converter type		ADS1256, 24-bit Sigma Delta
A/D data rates		3750 S/s, 2000 S/s, 1000 S/s, 500 S/s, 100 S/s, 60 S/s, 50 S/s, 25 S/s, 10 S/s, 5 S/s, 2.5 S/s
Throughput		<ul style="list-style-type: none"> ▪ Single channel: 2.5 S/s to 1102.94 S/s (software-selectable) ▪ Multiple channels: 0.16 S/s to 551.47 S/s (software-selectable) See Table 11 and Table 12 for details.
Number of channels		16 single-ended or 8 differential (software-selectable). Thermocouples require differential mode. For each channel configured as differential, you essentially lose two single-ended channels.
<i>Input isolation</i>		<i>500 VDC min between field wiring and USB interface</i>
Channel configurations		Temperature sensor input, software-selectable to match sensor type
		Voltage input
Input voltage range	Thermocouple mode	± 0.078125 V
	Voltage mode (Note 1)	± 10 V, ± 5 V, ± 2.5 V, ± 1.25 V, ± 0.625 V, ± 0.3125 V, ± 0.15625 V, ± 0.078125 V (software-selectable)
<i>Absolute maximum input voltage</i>	<i>CxH-CxL relative to GND</i>	<ul style="list-style-type: none"> ▪ ± 22 V max (power on) ▪ ± 10 V max (power off)
<i>Input impedance</i>		<ul style="list-style-type: none"> ▪ 10 MΩ (power on) ▪ 390 Ω (power off)
<i>Input leakage current</i>		± 20 nA
	<i>Input voltage > ± 30 V (power on/off)</i>	± 1 μ A max
Input capacitance		590 pf
Maximum working voltage (signal + common mode)	Voltage mode	± 10.25 V max
<i>Common mode rejection ratio (Note 1)</i>	<i>Thermocouple mode, (f_{IN} = 60 Hz)</i>	110 dB
	<i>Voltage mode, (f_{IN} = 60 Hz, all input ranges)</i>	90 dB
ADC resolution		24 bits
Crosstalk	Adj chan, DIFF mode	100 dB
Input coupling		DC
Channel gain queue	Up to 64 elements	Software-selectable channel and range
Warm-up time		45 minutes min
Open thermocouple detect		Software-selectable for each channel.
<i>CJC sensor accuracy</i>	<i>15 °C to 35 °C</i>	± 0.5 °C typ
	<i>0 °C to 55 °C</i>	± 1.0 °C max

Note 1: Placing a notch of the A/D digital filter at 60 Hz (setting A/D data rate = 60 S/s, 10 S/s, 5 S/s or 2.5 S/s) further improves the common mode rejection of this frequency.

Channel configurations

When any item is changed, the firmware stores channel configurations in the EEPROM of the isolated microcontroller. An external application issues commands over the USB to make changes, and the configuration is made non-volatile through the use of the EEPROM.

When connecting differential voltage inputs to a floating voltage source, provide a DC return path from each voltage input to ground. To do this, connect a resistor from each input to an AGND pin. A value of approximately 100 k Ω can be used for most applications. Leave unused input channels either floating or tied to AGND. For each voltage/thermocouple channel configured as differential, you essentially lose one single-ended channel.

Keep source impedances as small as possible to avoid settling time and accuracy errors.

Table 2. Channel configurations

Channel	Category	Specification
CxH/CxL	Thermocouple	8 differential channels
CxH/CxL	Voltage	16 individually-configurable channels that can be configured as either single-ended or 8 differential.
CxH/CxL	Voltage	

Compatible sensors

Table 3. Compatible sensor type specifications

Parameter	Conditions
Thermocouple	J: -210 °C to 1200 °C
	K: -270 °C to 1372 °C
	R: -50 °C to 1768 °C
	S: -50 °C to 1768 °C
	T: -270 °C to 400 °C
	N: -270 °C to 1300 °C
	E: -270 °C to 1000 °C
	B: 0 °C to 1820 °C

Accuracy

Thermocouple measurement accuracy

Thermocouple measurement accuracy specifications include polynomial linearization error, cold-junction compensation measurement error, and are for sample rates up to 60S/s. These specs are for one year, or 3000 operating hours, whichever comes first.

There is a CJC sensor for each terminal block of the module. The accuracy listed below assumes the screw terminals are at the same temperature as the CJC sensor.

The accuracy errors shown do not include the inherent accuracy error of the thermocouple sensor itself. Contact your thermocouple supplier for details on the actual thermocouple sensor accuracy limitations.

Connect thermocouples to the USB-2408 Series device such that they are floating with respect to AGND .

When configuring thermocouple sensors, keep any stray capacitance relative to AGND as small as possible to avoid settling time and accuracy errors.

The AGND and DGND pins are isolated from earth ground. You can connect thermocouple sensors to voltages referenced to earth ground as long as isolation between the AGND/DGND pins and earth ground is maintained.

Table 4. Thermocouple accuracy specifications, including CJC measurement error.
All specifications are (\pm).

Thermocouple	Sensor temperature range	Accuracy error, maximum	Accuracy error, typical	Tempco ($^{\circ}\text{C}/^{\circ}\text{C}$)
J	-210 $^{\circ}\text{C}$	2.572 $^{\circ}\text{C}$	1.416 $^{\circ}\text{C}$	0.022
	0 $^{\circ}\text{C}$	0.935 $^{\circ}\text{C}$	0.469 $^{\circ}\text{C}$	
	1200 $^{\circ}\text{C}$	1.869 $^{\circ}\text{C}$	1.456 $^{\circ}\text{C}$	
K	-210 $^{\circ}\text{C}$	2.917 $^{\circ}\text{C}$	1.699 $^{\circ}\text{C}$	0.029
	0 $^{\circ}\text{C}$	1.017 $^{\circ}\text{C}$	0.526 $^{\circ}\text{C}$	
	1372 $^{\circ}\text{C}$	2.478 $^{\circ}\text{C}$	2.022 $^{\circ}\text{C}$	
N	-200 $^{\circ}\text{C}$	3.480 $^{\circ}\text{C}$	2.030 $^{\circ}\text{C}$	0.029
	0 $^{\circ}\text{C}$	1.201 $^{\circ}\text{C}$	0.659 $^{\circ}\text{C}$	
	1300 $^{\circ}\text{C}$	1.991 $^{\circ}\text{C}$	1.600 $^{\circ}\text{C}$	
R	-50 $^{\circ}\text{C}$	4.826 $^{\circ}\text{C}$	3.133 $^{\circ}\text{C}$	0.082
	250 $^{\circ}\text{C}$	2.117 $^{\circ}\text{C}$	1.424 $^{\circ}\text{C}$	
	1768 $^{\circ}\text{C}$	2.842 $^{\circ}\text{C}$	2.347 $^{\circ}\text{C}$	
S	-50 $^{\circ}\text{C}$	4.510 $^{\circ}\text{C}$	2.930 $^{\circ}\text{C}$.089
	250 $^{\circ}\text{C}$	2.165 $^{\circ}\text{C}$	1.468 $^{\circ}\text{C}$	
	1768 $^{\circ}\text{C}$	3.187 $^{\circ}\text{C}$	2.597 $^{\circ}\text{C}$	
B	250 $^{\circ}\text{C}$	5.489 $^{\circ}\text{C}$	3.956 $^{\circ}\text{C}$	0.14
	700 $^{\circ}\text{C}$	2.283 $^{\circ}\text{C}$	1.743 $^{\circ}\text{C}$	
	1820 $^{\circ}\text{C}$	2.202 $^{\circ}\text{C}$	1.842 $^{\circ}\text{C}$	
E	-200 $^{\circ}\text{C}$	2.413 $^{\circ}\text{C}$	1.352 $^{\circ}\text{C}$	0.017
	0 $^{\circ}\text{C}$	1.069 $^{\circ}\text{C}$	0.551 $^{\circ}\text{C}$	
	1000 $^{\circ}\text{C}$	1.575 $^{\circ}\text{C}$	1.211 $^{\circ}\text{C}$	
T	-200 $^{\circ}\text{C}$	2.821 $^{\circ}\text{C}$	1.676 $^{\circ}\text{C}$	0.027
	0 $^{\circ}\text{C}$	1.050 $^{\circ}\text{C}$	0.558 $^{\circ}\text{C}$	
	400 $^{\circ}\text{C}$	0.957 $^{\circ}\text{C}$	0.595 $^{\circ}\text{C}$	

To achieve the thermocouple accuracies listed above, warm up the USB-2408 Series device for 45 minutes after the initial power on. The accuracies listed above are only guaranteed if the device is housed in the plastic enclosure.

Analog input DC voltage measurement accuracy

Table 5. DC Accuracy components and specifications. All values are (\pm).

Range	Gain error (% of reading)	Offset error	INL error (% of range)	Absolute accuracy	Gain temperature coefficient (% reading/ $^{\circ}\text{C}$)	Offset temperature coefficient ($\mu\text{V}/^{\circ}\text{C}$)
$\pm 10\text{ V}$	0.0037	50 μV	0.0008	500 μV	0.0006	3
$\pm 5\text{ V}$	0.0047	25 μV	0.0008	300 μV	0.0006	2
$\pm 2.5\text{ V}$	0.0059	20 μV	0.0008	200 μV	0.0006	1
$\pm 1.25\text{ V}$	0.0056	20 μV	0.0008	100 μV	0.0006	1
$\pm 0.625\text{ V}$	0.0068	15 μV	0.0005	60 μV	0.0006	1
$\pm 0.3125\text{ V}$	0.0104	15 μV	0.0006	50 μV	0.0006	1
$\pm 0.15625\text{ V}$	0.0184	10 μV	0.0005	40 μV	0.0006	1
$\pm 0.078125\text{ V}$	0.0384	10 μV	0.0009	40 μV	0.0006	1

Input bandwidth

Table 6. input bandwidth

A/D data rate	-3 db Bandwidth (Hz)
3750 S/s	1615
2000 S/s	878
1000 S/s	441
500 S/s	221
100 S/s	44.2
60 S/s	26.5
50 S/s	22.1
25 S/s	11.1
10 S/s	4.42
5 S/s	2.21
2.5 S/s	1.1

Noise performance

For the peak-to-peak noise distribution test, a differential input channel is connected to AGND at the input terminal block, and 50,000 samples are acquired at the maximum rate available at each setting.

Table 7. Peak-to-peak noise performance specifications (μV)

Range	A/D data rate										
	3750 S/s	2000 S/s	1000 S/s	500 S/s	100 S/s	60 S/s	50 S/s	25 S/s	10 S/s	5 S/s	2.5 S/s
$\pm 10\text{ V}$	126.84	15.17	10.87	6.83	4.62	4.62	4.05	2.89	1.81	1.44	1.44
$\pm 5\text{ V}$	56.74	7.21	5.18	3.92	2.46	2.17	2.17	2.16	0.90	0.72	0.72
$\pm 2.5\text{ V}$	32.96	4.36	2.72	2.15	1.14	1.07	1.07	0.87	0.58	0.60	0.60
$\pm 1.25\text{ V}$	18.57	2.66	2.10	1.41	0.83	0.83	0.76	0.58	0.51	0.51	0.43
$\pm 0.625\text{ V}$	18.88	2.51	1.28	1.12	0.81	0.73	0.66	0.58	0.38	0.40	0.30
$\pm 0.3125\text{ V}$	15.33	2.24	1.24	1.05	0.72	0.71	0.68	0.56	0.51	0.39	0.37
$\pm 0.15625\text{ V}$	13.28	2.55	1.13	1.00	0.86	0.68	0.68	0.64	0.40	0.47	0.35
$\pm 0.078125\text{ V}$	13.47	2.28	1.39	1.04	0.65	0.63	0.60	0.54	0.35	0.32	0.36

Table 8. RMS noise performance specifications (μVRMS)

Range	A/D data rate										
	3750 S/s	2000 S/s	1000 S/s	500 S/s	100 S/s	60 S/s	50 S/s	25 S/s	10 S/s	5 S/s	2.5 S/s
$\pm 10\text{ V}$	19.22	15.17	10.87	6.83	4.62	4.62	4.05	2.89	1.81	1.44	1.44
$\pm 5\text{ V}$	8.60	7.21	5.18	3.92	2.46	2.17	2.17	2.16	0.90	0.72	0.72
$\pm 2.5\text{ V}$	4.99	4.36	2.72	2.15	1.14	1.07	1.07	0.87	0.58	0.60	0.60
$\pm 1.25\text{ V}$	2.81	2.66	2.10	1.41	0.83	0.83	0.76	0.58	0.51	0.51	0.43
$\pm 0.625\text{ V}$	2.86	2.51	1.28	1.12	0.81	0.73	0.66	0.58	0.38	0.40	0.30
$\pm 0.3125\text{ V}$	2.32	2.24	1.24	1.05	0.72	0.71	0.68	0.56	0.51	0.39	0.37
$\pm 0.15625\text{ V}$	2.01	2.55	1.13	1.00	0.86	0.68	0.68	0.64	0.40	0.47	0.35
$\pm 0.078125\text{ V}$	2.04	2.28	1.39	1.04	0.65	0.63	0.60	0.54	0.35	0.32	0.36

Table 9. Noise-free resolution specifications (bits)

Range	A/D data rate										
	3750 S/s	2000 S/s	1000 S/s	500 S/s	100 S/s	60 S/s	50 S/s	25 S/s	10 S/s	5 S/s	2.5 S/s
$\pm 10\text{ V}$	17.2	17.6	18.1	18.7	19.3	19.3	19.5	20.0	20.6	21.0	21.0
$\pm 5\text{ V}$	17.4	17.6	18.1	18.5	19.2	19.4	19.4	19.4	20.6	21.0	21.0
$\pm 2.5\text{ V}$	17.2	17.4	18.1	18.4	19.3	19.4	19.4	19.7	20.3	20.7	21.0
$\pm 1.25\text{ V}$	17.0	17.1	17.4	18.0	18.8	18.8	18.9	19.3	19.5	19.5	19.7

±0.625 V	16.0	16.2	17.1	17.3	17.8	18.0	18.1	18.3	18.9	18.8	19.2
±0.3125 V	15.3	15.3	16.2	16.4	17.0	17.0	17.0	17.3	17.5	17.9	17.9
±0.15625 V	14.5	14.1	15.3	15.5	15.7	16.1	16.1	16.1	16.8	16.9	17.1
±0.078125 V	14.5	14.3	15.0	15.4	16.1	16.2	16.2	16.4	17.0	17.1	16.9

Channel switching error

Table 10. Step response accuracy specifications

Range	Accuracy										
	3750 S/s	2000 S/s	1000 S/s	500 S/s	100 S/s	60 S/s	50 S/s	25 S/s	10 S/s	5 S/s	2.5 S/s
±10 V	0.0010%	0.0008%	0.0005%	0.0004%	0.0002%	0.0002%	0.0003%	0.0002%	0.0001%	0.0001%	0.0001%
±5 V	0.0009%	0.0008%	0.0004%	0.0004%	0.0003%	0.0002%	0.0002%	0.0002%	0.0001%	0.0001%	0.0001%
±2.5 V	0.0010%	0.0007%	0.0008%	0.0004%	0.0003%	0.0002%	0.0002%	0.0002%	0.0002%	0.0001%	0.0001%
±1.25 V	0.0013%	0.0009%	0.0008%	0.0007%	0.0004%	0.0004%	0.0003%	0.0003%	0.0003%	0.0003%	0.0003%
±0.625 V	0.0022%	0.0016%	0.0011%	0.0011%	0.0007%	0.0007%	0.0005%	0.0005%	0.0004%	0.0005%	0.0003%
±0.3125 V	0.0031%	0.0031%	0.0020%	0.0017%	0.0015%	0.0012%	0.0010%	0.0010%	0.0012%	0.0009%	0.0009%
±0.15625 V	0.0056%	0.0062%	0.0048%	0.0037%	0.0032%	0.0025%	0.0024%	0.0021%	0.0019%	0.0022%	0.0016%
±0.078125 V	0.0114%	0.0123%	0.0076%	0.0070%	0.0041%	0.0051%	0.0046%	0.0036%	0.0032%	0.0030%	0.0034%

Channel switching error is defined as the accuracy that can be expected after one conversion when switching from a channel with a DC input at one extreme of full scale to another channel with a DC input at the other extreme of full scale, expressed in terms of percentage of full scale value.

Throughput rate

The single channel throughput rate is calculated using this formula:

$$Maximum\ throughput = \frac{1}{data\ rate} + 640\mu s$$

Table 11. Single channel throughput rate specifications

A/D data rate	Maximum throughput (Hz)
3750 S/s	1102.94
2000 S/s	877.19
1000 S/s	609.76
500 S/s	378.79
100 S/s	93.98
60 S/s	57.78
50 S/s	48.45
25 S/s	24.61
10 S/s	9.94
5 S/s	4.98
2.5 S/s	2.50

The multiple-channel throughput rate is calculated using this formula:

$$Maximum\ throughput = \frac{1}{\sum_n \left(\frac{1}{data\ rate} + 640\mu s \right)}, \text{ where } n \text{ is the number of channels}$$

Table 12. Multiple-channel throughput rate specifications (Hz)

Number of input channels	3750 S/s	2000 S/s	1000 S/s	500 S/s	100 S/s	60 S/s	50 S/s	25 S/s	10 S/s	5 S/s	2.5 S/s
1	1102.94	877.19	609.76	378.79	93.98	57.78	48.45	24.61	9.94	4.98	2.50
2	551.47	438.60	304.88	189.39	46.99	28.89	24.22	12.30	4.97	2.49	1.25
3	367.65	292.40	203.25	126.26	31.33	19.26	16.15	8.20	3.31	1.66	0.83
4	275.74	219.30	152.44	94.70	23.50	14.45	12.11	6.15	2.48	1.25	0.62
5	220.59	175.44	121.95	75.76	18.80	11.56	9.69	4.92	1.99	1.00	0.50
6	183.82	146.20	101.63	63.13	15.66	9.63	8.07	4.10	1.66	0.83	0.42
7	157.56	125.31	87.11	54.11	13.43	8.25	6.92	3.52	1.42	0.71	0.36
8	137.87	109.65	76.22	47.35	11.75	7.22	6.06	3.08	1.24	0.62	0.31
9	122.55	97.47	67.75	42.09	10.44	6.42	5.38	2.73	1.10	0.55	0.28
10	110.29	87.72	60.98	37.88	9.40	5.78	4.84	2.46	0.99	0.50	0.25
11	100.27	79.74	55.43	34.44	8.54	5.25	4.40	2.24	0.90	0.45	0.23
12	91.91	73.10	50.81	31.57	7.83	4.82	4.04	2.05	0.83	0.42	0.21
13	84.84	67.48	46.90	29.14	7.23	4.44	3.73	1.89	0.76	0.38	0.19
14	78.78	62.66	43.55	27.06	6.71	4.13	3.46	1.76	0.71	0.36	0.18
15	73.53	58.48	40.65	25.25	6.27	3.85	3.23	1.64	0.66	0.33	0.17
16	68.93	54.82	38.11	23.67	5.87	3.61	3.03	1.54	0.62	0.31	0.16

Analog voltage output (USB-2408-2AO only)

Unused AOUTx output channels should be left disconnected.

The USB-2408-2AO output voltage level defaults to 0 V whenever the host PC is reset, shut down or suspended, or if a reset command is issued to the device.

The outputs may have a transient during startup. The duration of the output transient depends highly on the enumeration process of the host PC. Typically, the output of the USB-2408-2AO is stable after two seconds.

Table 13. USB-2408-2AO analog voltage output specifications

Parameter	Conditions	Specifications
Digital-to-analog converter		DAC8552
Number of channels		2
Resolution		16 bits
Output ranges	Calibrated	± 10 V
	Uncalibrated	± 10.05 V (software-selectable)
Output transient	Host PC is reset, powered on, suspended or a reset command is issued to device	Duration: 2 s Amplitude: 2 V p-p
	Initial power on	Duration: 50 ms Amplitude: 5 V peak
Differential non-linearity		± 0.25 LSB typ ± 1 LSB max
Output current	AOUTx pins	± 5.0 mA max
Output short-circuit protection	AOUTx connected to AGND	Unlimited duration
Output coupling		DC
Power on and reset state		DACs cleared to zero-scale: 0 V, ± 50 mV
Output noise		$60 \mu\text{V}_{\text{rms}}$ (BW=1.5 KHz)
Settling time	To rated accuracy, 10 V step	75 μs
Slew rate		1.0 V/ μs

Parameter	Conditions	Specifications
Throughput	Single-channel	1000 S/s max, system-dependent, 0.01 S/s min
	Multi-channel	1000 S/s / #ch max, system-dependent, 0.01 S/s min

Table 14. Calibrated absolute accuracy specifications

Range	Accuracy (\pm LSB)
± 10 V	16.0

Table 15. Calibrated absolute accuracy components specifications

Range	% of reading	Offset (\pm mV)	Temp drift ($\%$ / $^{\circ}$ C)	Absolute accuracy at FS (\pm mV)
± 10 V	± 0.0183	1.831	0.00055	3.661

Table 16. Relative accuracy specifications

Range	Relative accuracy (\pm LSB)
± 10 V	4.0 typ

Analog input/output calibration

Table 17. Analog input/output calibration specifications

Parameter	Specifications
Recommended warm-up time	45 minutes min
Calibration	Firmware calibration
Calibration interval	1 year
AI calibration reference	+10.000 V, ± 5 mV max. Actual measured values stored in EEPROM
	Tempco: 5 ppm/ $^{\circ}$ C max
	Long term stability: 30 ppm/1000 hours
AO calibration procedure (USB-2408-2AO only)	The analog output pin is internally routed to the analog input pin.
AOUTx readback (USB-2408-2AO only)	Each AOUTx output can be independently measured by the onboard A/D converter. Software-selectable

Digital input/output

Table 18. Digital input specifications

Parameter	Specifications
Number of I/O	8 channels
Configuration	Each DIO bit can be independently read from (DIN) or written to (DOUT). The DIN bits can be read at any time whether the DOUT is active or tri-stated.
Input voltage range	0 to +15 V
Input type	CMOS (Schmitt trigger)
Input characteristics	47 k Ω pull-up/pull-down resistor, 28 k Ω series resistor
Maximum input voltage range	0 V to +20 V max (power on/off, relative to DGND) (Note 2)
Pull-up/pull-down configuration	All pins pulled up to +5 V via individual 47 k Ω resistors (the J6 shorting block default position is pins 1 and 2). Pull down capability is available by placing the J6 shorting block across pins 2 and 3.
Transfer rate (software paced)	500 port reads or single bit reads per second typ.
Input high voltage	1.3 V min, 2.2 V max
Input low voltage	1.5 V max, 0.6 V min
Schmitt trigger hysteresis	0.4 V min, 1.2 V max

Note 2: DGND pins are recommended for use with digital input and digital output pins. The DGND and AGND pins are common and are isolated from earth ground.

Table 19. Digital output specifications

Parameter	Specifications
Number of I/O	8 channels
Configuration (Note3)	Each DIO bit can be independently read from (DIN) or written to (DOUT). The DIN bits may be read at any time whether the DOUT is active or tri-stated
Output characteristics (Note 4)	47 k Ω pull-up, open drain (DMOS transistor)
Pull-up configuration	All pins pulled up to +5 V via individual 47 k Ω resistors (the J6 shorting block default position is pins 1 and 2).
Transfer rate (software paced)	Digital output – 500 port writes or single-bit writes per second typ.
Output voltage range	0 V to +5 V (no external pull up resistor, internal 47 k Ω pull-up resistors connected to +5 V by default) 0 V to +15 V max (Note 5)
Drain to source breakdown voltage	+50 V min
Off state leakage current (Note 6)	1.0 μ A
Sink current capability	<ul style="list-style-type: none"> ▪ 150 mA max (continuous) per output pin ▪ 150 mA max (continuous) for all eight channels
DMOS transistor on-resistance (drain to source)	4 Ω

Note 3: DGND pins are recommended for use with digital input and digital output pins. The DGND and AGND pins are common and are isolated from earth ground.

Note 4: Each DMOS transistor source pin is internally connected to DGND.

Note 5: The external pull-up is connected to the digital output bit through an external pull-up resistor. Adding an external pull-up resistor connects it in parallel with the internal 47 k Ω pull-up resistor of that particular digital input/output bit. Careful consideration should be made when considering the external pull-up resistor value and the resultant pull-up voltage produced at the load.

Note 6: Does not include the additional leakage current contribution that may occur when using an external pull-up resistor.

Counter

Table 20. CTR specifications

Parameter	Conditions	Specification
Pin name		CTR0, CTR1
Number of channels		2 channels
Resolution		32-bits
Counter type		Event counter
Input type		Schmitt trigger, rising edge triggered
Input source		CTR0 (pin 44) CTR1 (pin 42)
Counter read/writes rates (software paced)	Counter read	System dependent, 500 reads per second.
	Counter write	System dependent, 500 writes per second.
Input characteristics	Each CTRx input pin	562 k Ω pull-up resistor to +5 V, 10 k Ω series resistor
Input voltage range		\pm 15 V max
Max input voltage range	CTR0, CTR1 relative to AGND and DGND (Note 7)	\pm 20 V max (power on/off)
Input high voltage		1.3 V min, 2.2 V max
Input low voltage		1.5 V max, 0.6 V min

Schmitt trigger hysteresis		0.4 V min, 1.2 V max
Input bandwidth (-3 dB)		1 MHz
Input capacitance		25 pf
Input leakage current		± 120 nA@5 V, ± 1.6 mA@ ± 15 V
Input frequency		1 MHz, max
High pulse width		500 ns, min
Low pulse width		500 ns, min

Note 7: DGND pins are recommended for use with counter input pins. The DGND and AGND are common and are isolated from earth ground.

Memory

Table 21. Memory specifications

EEPROM	4096 bytes isolated micro reserved for sensor configuration 256 bytes USB micro for external application use
--------	---

Microcontroller

Table 22. Microcontroller specifications

Type	One high-performance 8-bit RISC microcontroller with USB interface (non-isolated) One high-performance 16-bit RISC microcontroller for measurements (isolated)
------	---

Power

Table 23. Power specifications

Parameter	Conditions	Specification
Supply current (Note 8)	Quiescent current	275 mA
Voltage supervisor limits	$4.5\text{ V} > V_{\text{ext}}$ or $V_{\text{ext}} > 5.5\text{ V}$	PWR LED = Off; (power fault)
	$4.5\text{ V} < V_{\text{ext}} < 5.5\text{ V}$	PWR LED = On
+5 V user output voltage range	Available at terminal block pin 40	4.75 V min to 5.25 V max
+5 V user output current	Available at terminal block pin 40	10 mA max
Isolation	Measurement system to PC	500 VDC min

Note 8: This is the total quiescent current requirement for the USB-2408 Series which includes up to 10 mA for the status LED. This does not include any potential loading of the digital I/O bits, +5 V user terminal or the AOUTx outputs.

USB specifications

Table 24. USB specifications

Parameter	Specifications
USB device type	USB 2.0 (full-speed)
Device compatibility	USB 1.1, USB 2.0
USB cable type	A-B cable, UL type AWM 2527 or equivalent. (min 24 AWG VBUS/GND, min 28 AWG D+/D-)
USB cable length	3 meters max

Environmental

Table 25. Environmental specifications

Parameter	Specifications
Operating temperature range	0 °C to 50 °C max

Storage temperature range	-40 °C to 85 °C max
Humidity	0 to 90% non-condensing max

Mechanical

Table 26. Mechanical specifications

Parameter	Specifications
Dimensions (L x W x H)	127 × 89.9 × 35.6 mm (5.00 x 3.53 x 1.40 in.)
User connection length	3 meters max

Screw terminal connector type and pinout

Table 27. Screw terminal connector specifications

Connector type	Fixed screw terminal
Wire gauge range	16 AWG to 30 AWG

Screw terminal pinout

Table 28. 8-channel differential mode pinout

Pin	Signal name	Pin description	Pin	Signal name	Pin description
1	CH0H	Channel 0 HI	23	AGND	Analog ground
2	CH0L	Channel 0 LO	24	CH7L	Channel 7 LO
3	AGND	Analog ground	25	CH7H	Channel 7 HI
4	CH1H	Channel 1 HI	26	AGND	Analog ground
5	CH1L	Channel 1 LO	27	CH6L	Channel 6 LO
6	AGND	Analog ground	28	CH6H	Channel 6 HI
7	CH2H	Channel 2 HI	29	AGND	Analog ground
8	CH2L	Channel 2 LO	30	CH5L	Channel 5 LO
9	AGND	Analog ground	31	CH5H	Channel 5 HI
10	CH3H	Channel 3 HI	32	AGND	Analog ground
11	CH3L	Channel 3 LO	33	CH4L	Channel 4 LO
12	AGND	Analog ground	34	CH4H	Channel 4 HI
13	DGND	Digital ground	35	AGND	Analog ground
14	DIO0	Digital input/output	36	AOUT1 (Note 9)	Analog output 1
15	DIO1	Digital input/output	37	AGND	Analog ground
16	DIO2	Digital input/output	38	AOUT0 (Note 9)	Analog output 0
17	DIO3	Digital input/output	39	CHAS	Chassis ground
18	DIO4	Digital input/output	40	+5V	+5 V output
19	DIO5	Digital input/output	41	DGND	Digital ground
20	DIO6	Digital input/output	42	CTR1	Counter 1
21	DIO7	Digital input/output	43	DGND	Digital ground
22	DGND	Digital ground	44	CTR0	Counter 0

Note 9: On the USB-2408, these pins are labeled NC (no connection).

Table 29. 16-channel single-ended mode pinout

Pin	Signal name	Pin description	Pin	Signal name	Pin description
1	CH0	Channel 0	23	AGND	Analog ground
2	CH8	Channel 8	24	CH15	Channel 15
3	AGND	Analog ground	25	CH7	Channel 7
4	CH1	Channel 1	26	AGND	Analog ground
5	CH9	Channel 9	27	CH14	Channel 14
6	AGND	Analog ground	28	CH6	Channel 6
7	CH2	Channel 2	29	AGND	Analog ground
8	CH10	Channel 10	30	CH13	Channel 13
9	AGND	Analog ground	31	CH5	Channel 5
10	CH3	Channel 3	32	AGND	Analog ground
11	CH11	Channel 11	33	CH12	Channel 12
12	AGND	Analog ground	34	CH4	Channel 4
13	DGND	Digital ground	35	AGND	Analog ground
14	DIO0	Digital input/output	36	AOUT1 (Note 10)	Analog output 1
15	DIO1	Digital input/output	37	AGND	Analog ground
16	DIO2	Digital input/output	38	AOUT0 (Note 10)	Analog output 0
17	DIO3	Digital input/output	39	CHAS	Chassis ground
18	DIO4	Digital input/output	40	+5V	+5 V output
19	DIO5	Digital input/output	41	DGND	Digital ground
20	DIO6	Digital input/output	42	CTR1	Counter 1
21	DIO7	Digital input/output	43	DGND	Digital ground
22	DGND	Digital ground	44	CTR0	Counter 0

Note 10: On the USB-2408, these pins are labeled NC (no connection).

CE Declaration of Conformity

Manufacturer: Measurement Computing Corporation
Address: 10 Commerce Way
Suite 1008
Norton, MA 02766
USA
Category: Electrical equipment for measurement, control and laboratory use.

Measurement Computing Corporation declares under sole responsibility that the products

USB-2408, USB-2408-2AO

to which this declaration relates is in conformity with the relevant provisions of the following standards or other documents:

EC EMC Directive 2004/108/EC: General Requirements, EN 61326-1:2006 (IEC 61326-1:2005).

Emissions:

- EN 55011 (2007) / CISPR 11(2003): Radiated emissions: Group 1, Class A
- EN 55011 (2007) / CISPR 11(2003): Conducted emissions: Group 1, Class A

Immunity: EN 61326-1:2006, Table 3.

- IEC 61000-4-2 (2001): Electrostatic Discharge immunity.
- IEC 61000-4-3 (2002): Radiated Electromagnetic Field immunity.
-
- To maintain compliance to the standards of this declaration, the following conditions must be met.
-
- The host computer, peripheral equipment, power sources, and expansion hardware must be CE compliant.
- All I/O cables must be shielded, with the shields connected to ground.
- I/O cables must be less than 3 meters (9.75 feet) in length.
- The host computer must be properly grounded.
- The host computer must be USB 2.0 compliant.
- Equipment must be operated in a controlled electromagnetic environment as defined by Standards EN 61326-1:2006, or IEC 61326-1:2005.

Note: Data acquisition equipment may exhibit noise or increased offsets when exposed to high RF fields (>1V/m) or transients.

Declaration of Conformity based on tests conducted by Chomerics Test Services, Woburn, MA 01801, USA in November, 2010. Test records are outlined in Chomerics Test Report #EMI5755.10.

We hereby declare that the equipment specified conforms to the above Directives and Standards.



Carl Haapaoja, Director of Quality Assurance

Measurement Computing Corporation
10 Commerce Way
Suite 1008
Norton, Massachusetts 02766
(508) 946-5100
Fax: (508) 946-9500
E-mail: info@mccdaq.com
www.mccdaq.com